

Sapphire Engineering™ VFP17

Precision Dispense Pump

Finally, the value, flexibility, and performance you require. With its zirconia ceramic displacement piston technology, the VFP17 precision dispense pump offers several key benefits over competing displacement and syringe pumps, including:

- ▶ High precision and low cost of ownership at a value price to meet the cost constraints of lab automation and diagnostic applications
- ▶ Guaranteed pump life of millions of cycles
- ▶ Available with total dispense volumes of 25 µL to 5 mL
- ▶ Flexibility to customize for your application
- ▶ Now available in custom screw thread pitches
- ▶ Now available in two motor choices, 1.2 amps for fast-dispense applications or .85 amp for high pressure applications

Features

- ▶ A robust, precise Frame 17, 1.8 degree stepper motor – bipolar, 24V DC Operation
- ▶ Standard 40 and 20 pitch lead screws with custom screw thread pitches available
- ▶ Optical home sensor – standard
- ▶ Pump-head material choices of acrylic, Ultem®, PEEK™, and other polymers available upon request
- ▶ Optional seal wash to maximize seal life with difficult fluids
- ▶ Optional optical encoder for stepper motor feedback
- ▶ Accurate dispense volumes less than 1% CV when tested using DI water
- ▶ Flexible pump-head design allowing easy integration with valves, manifolds, and other components

For more information please contact Sapphire Engineering or your local OEM Representative.



Value, Flexibility, Performance: VFP

Principle of Operation

Sapphire's Positive Displacement Pumps contain a ceramic piston, precision lapped to a diameter tolerance of 0.0001" / 0.0025 mm. As the piston moves through a stationary seal, it displaces the exact volume of the piston extended within the pump head. A lead-screw controlled by a micro-stepping stepper motor, extends and retracts the piston accurately and precisely.

Overall Dimensions

Dimensions given in inches and (millimeters)

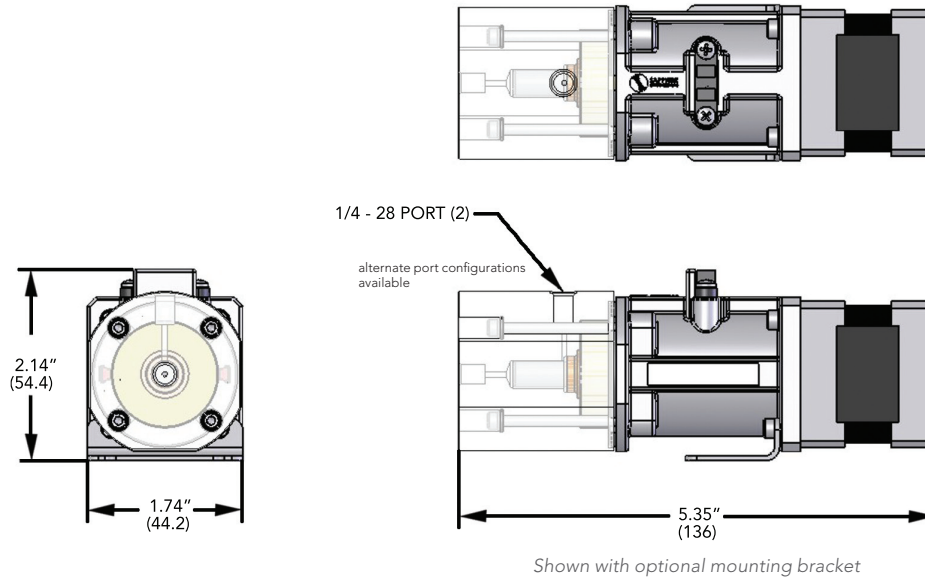

General Specifications

Total Pump Volume	Approximate Volume Dispensed (μL / Full Step)		Piston Specifications
	40 Pitch Thread	20 Pitch Thread	
25 μL	0.00625	0.0125	0.0623" x 0.5" (1.582 x 12.7)
50 μL	0.0125	0.0250	0.0881" x 0.5" (2.240 x 12.7)
100 μL	0.0250	0.0500	0.1246" x 0.5" (3.170 x 12.7)
250 μL	0.0625	0.1250	0.1971" x 0.5" (5.006 x 12.7)
500 μL	0.1250	0.2500	0.2787" x 0.5" (7.079 x 12.7)
1.0 mL	0.2500	0.5000	0.3942" x 0.5" (10.013 x 12.7)
2.5 mL	0.6250	1.2500	0.6232" x 0.5" (15.829 x 12.7)
5.0 mL	1.2500	2.5000	0.8814" x 0.5" (22.388 x 12.7)
Motor Linear Resolution¹	0.000125" (0.00318)	0.000250" (0.00635)	

1. Inches of piston travel per full step

Motor Specifications

	High Speed Motor (Low Pressure)	High Torque Motor (High Pressure)
Phase Voltage	4V DC	5.6V DC
Phase Current	1.2 AMP	0.85 AMP
Phase Resistance	3.3 Ohms	6.6 Ohms
Phase Inductance	3.2 mH	12.8 mH
Other Info	BiPolar, 1.8 Degree Stepper Motor	BiPolar, 1.8 Degree Stepper Motor

PEEK™ polymer is a trademark of Victrex plc.
Ultem® is a registered trademark of General Electric Corporation.
©2009 IDEX Health & Science LLC

S4:500-02/2009